

**Shielding Effectiveness
Test Method for
Commercial Style EMI Gaskets
(Revision A)**

CHOMERICS 

 **Parker** Seals

1.0 SCOPE

1.1 This is a test method for performing shielding effectiveness measurements on commercial grade EMI gaskets in strip form. Materials that can be evaluated using this technique include homogeneously conductive gaskets, and conductive coating over non-conductive core gaskets with cross-sections less than .350 inch. Radiated methods in accordance with MIL-STD-285, except where noted, are used to determine shielding effectiveness.

1.2 This test method covers fixture design, specimen preparation, and instrumentation to characterize a conductive gasket system for shielding effectiveness.

1.3 The Chomerics gasket materials applicable to this Test Method are: CHO-SEAL® (homogeneous); CHO-SIL® materials (reticular); CHO-SEAL® 3000 materials (conductive coat over a silicone core); Soft Shield I materials (knitted wire over a sponge core); and Soft Shield II materials (knitted conductive yarn over a sponge core).

1.4 This test method does **not** duplicate the mechanical and/or electrical performance of a gasket in an actual electronic enclosure, but does allow evaluation of variations in gasket materials. The data obtained from these tests may or may not be equivalent to a gasket's performance when installed in an actual enclosure. Variables such as metal surface treatment, gasket deflection, flange deflection, fastener spacing, and the source, amplitude, and frequency of electromagnetic fields all play a part in the shielding effectiveness of a gasket system installed in an electronic enclosure. Care should be taken in applying the absolute values obtained from these tests to other gasket/flange geometries or enclosure designs.

2.0 APPLICABLE DOCUMENTS

2.1 MIL-STD-285: Attenuation measurements for enclosures, electromagnetic shielding, for electronic test purposes; method of. date; 25 June 1956.

2.2 CEPS-0002: Electrically Conductive Elastomers Volume Resistivity Measurement Procedures, 1991.

2.3 NSA 65-6: R.F. Shielded Enclosures for Communications Equipment; General Specification. date; 30 October 1964.

3.0 SIGNIFICANCE AND USE

3.1 Conductive EMI gaskets are used to seal apertures in electronic enclosures against leakage of electromagnetic radiation. Metal-filled elastomers (homogeneously conductive elastomers) are one type of EMI gasket used for this purpose. Conductive elastomers consist of small (typically, 30 to 150 micron) metal particles dispersed in an elastomer binder. Typical metal fillers include silver, silver plated materials (e.g., copper, glass, aluminum, nickel), nickel, and carbon. Typical binders include silicone, fluorosilicone, and EPDM. The elastomer binder is highly loaded with the metal filler to provide low volume resistivity. A second type of EMI gasket material incorporates a conductive coating or covering around a non-conductive core. The conductive layer can be in the form of a coating filled with conductive particles, a knitted or woven conductive fabric, or wire. In use, these conductive gasket materials are compressed between mating surfaces to form a low impedance bond.

3.2 The purpose of this test method is to determine the shielding effectiveness of "strip" form conductive gaskets made of materials with different physical and electrical properties.

3.3 This method is intended to provide a controlled test for comparison of different gasket materials in an R&D environment.

3.4 The shielding effectiveness is measured using a radiated field technique. This measurement technique corresponds to MIL-STD-285 and MIL-G-83528B, except, as noted, for the frequency range, the open reference test technique, and the sample and fastener configurations.

3.5 Three different open reference measurements are made to allow the final test data to be evaluated and/or compared by several different approaches. The open references taken are outlined in Section 5.0, Shielding Effectiveness Measurements.

4.0 TEST PREPARATION

4.1 Test Plates

4.1.1 Multiple test plates are required. Each test plate consists of a 0.250 inch thick 6061-T6 aluminum plate bonded or mechanically fastened to a layer (sheet) of polycarbonate (DuPont Lexan) to provide a non-conductive compression stop and gasket mounting system. If mechanical fasteners are used, they should be nonconductive and sufficiently countersunk so as not to protrude above the test plate surface.

4.1.2 These test plates, illustrated in Drawings 1A through 7B (see Appendix), adapt to the opening and bolt pattern on Chomerics' shielded enclosure (test chamber). The non-conductive "spacers" are sized to allow proper deflection of the various gasket sizes. An assortment of test plates with spacers of differing thicknesses will allow different gaskets to be evaluated under their proper deflection parameters.

4.1.3 The following test plates have been designed (dimensions in inches):

1. Drawings 1A and 1B: ALR-93-014-1, groove depth 0.047 ± 0.002 and groove width 0.080 ± 0.002 .
2. Drawings 2A and 2B: ALR-93-014-2, groove depth 0.075 ± 0.002 and groove width 0.106 ± 0.002 .
3. Drawings 3A and 3B: ALR-93-014-3, groove depth 0.104 ± 0.002 and groove width 0.133 ± 0.002 .
4. Drawings 4A and 4B: ALR-93-014-4, groove depth 0.050 ± 0.002 and groove width 0.350 ± 0.002 .
5. Drawings 5A and 5B: ALR-93-014-5, groove depth 0.091 ± 0.002 and groove width 0.139 ± 0.002 .

6. Drawings 6A and 6B: ALR-93-014-6, groove depth 0.190 ± 0.002 and groove width 0.250 ± 0.002 .

7. Drawings 7A and 7B: ALR-93-014-7, groove depth 0.152 ± 0.002 and groove width 0.199 ± 0.002 .

4.1.4 The preferred method is to use the test plates described above for consistent, repeatable test data; however, a plain sheet of 0.250 inch aluminum without the Lexan layer can also be used. In this case, holding the gasket in place while mounting the test plate to the vertical wall of the shielded enclosure is difficult, but can be done. Sagging and variations in the location of the gasket between the flanges can create inconsistencies in shielding values obtained by this method. Deflection of the gasket material can be controlled by adding plastic (non-conductive) shim stock, of proper thickness, between the test plate and mating flange in various locations around the plate. Non-conductive fasteners should be used to mount the test plate to the shielded room wall.

4.2 Sample Gasket Preparation

4.2.1 This test method was initially developed using a hollow "O" conductive elastomer gasket with an outside diameter of 0.250 inch and an inside diameter of 0.125 inch, and a solid "D" conductive elastomer gasket with a width of 0.175 inch and a height of 0.178 inch. The hollow "O" gasket and the solid "D" gasket were tested using Test Plates 6 and 7 defined above. Tests can also be performed with conductively coated non-conductive core gaskets.

4.2.2 The gasket configuration (not cross-section) is a square "picture frame" which has outside dimensions adequate to fit within the groove provided on the test plate. Fitting gaskets into the corners of the test plates can be handled in a number of ways. The preferred method is to use one piece of gasket material and "butt" together the ends. Alternatively, the gasket can be assembled from four strips cut at a 45 degree angle, with corners either butted together or spliced with a conductive compound.

4.2.3 The following gasket types and cross-sections are intended to be used with test plates described in Paragraph 4.1.3:

1. Drawings 1A and 1B, ALR-93-014-1, p/n 10-04-2561-XXXX, conductive elastomer 0.062 inch Diameter Solid "O" Extrusion. Nominal gasket deflection is 24.2%, maximum deflection is 32.8%, and minimum deflection is 10.5%.
2. Drawings 2A and 2B, ALR-93-014-2, p/n 10-04-2865-XXXX, conductive elastomer 0.093 inch Diameter Solid "O" Extrusion. Nominal gasket deflection is 19.4%, maximum deflection is 25.5%, and minimum deflection is 10.2%.
3. Drawings 3A and 3B, ALR-93-014-3, p/n 10-04-2463-XXXX, conductive elastomer 0.125 inch Diameter Solid "O" Extrusion. Nominal gasket deflection is 16.8%, maximum deflection is 21.5%, and minimum deflection is 10.0%.
4. Drawings 4A and 4B, ALR-93-014-4, p/n 10-07-3226-XXXX, conductive elastomer 0.062 inch thick by 0.250 inch wide Rectangular Strip Extrusion. Nominal gasket deflection is 19.4%, maximum deflection is 28.5%, and minimum deflection is 5.0%.
5. Drawings 5A and 5B, ALR-93-014-5, p/n 10-04-2999-XXXX, conductive elastomer 0.125 inch Outside Diameter by 0.062 inch Inside Diameter Hollow "O" Extrusion. Nominal gasket deflection is 27.2%, maximum deflection is 31.5%, and minimum deflection is 20.8%.
6. Drawings 6A and 6B, ALR-93-014-6, p/n 10-04-2737-XXXX, conductive elastomer 0.250 inch Outside Diameter by 0.125 inch Inside Diameter Hollow "O" Extrusion. Nominal gasket deflection is 24.0%, maximum deflection is 27.1%, and minimum deflection is 19.8%.
7. Drawings 7A and 7B, ALR-93-014-7, p/n 10-05-1577-XXXX, conductive elastomer 0.175 inch High by 0.178 inch Wide Solid "D" Extrusion. Nominal gasket deflection is 13.1%, maximum deflection is 16.7%, and minimum deflection is 8.2%.

4.2.4 The above gasket/groove combinations have been designed by Chomerics' Applications Lab Personnel to provide recommended gasket deflection ranges and to prevent groove overflow

which could damage the gaskets. Other gasket materials can be tested within the same test plate grooves, provided that the deflection parameters are suitable. Additional test plates will be required to provide proper gasket deflection for other gasket types and sizes.

4.3 The EMI test chamber must meet or exceed the following specifications:

A. Minimum size: 16 feet long x 12 feet wide x 8 feet high. The use of either stirred mode or anechoic chambers is acceptable, although not required. Figure 1 is an example of a shielded enclosure.

B. Attenuation tests must demonstrate that the shielded enclosure meets attenuation requirements in excess of NSA 65-6 and MIL-STD-285.

C. The available AC power within the shielded enclosure must be only 115V AC, single phase, 60 cycle for the test equipment operation. This power is required to be provided through line filters rated at 100 dB of attenuation from 10 kHz to 10 GHz.

D. Any unused aperture in the shielded enclosure should be covered with blank panels of aluminum or steel plate using metal fasteners, appropriate gaskets, and copper foil tape. The technique used must ensure that no leakage from such panels will affect measurements made on the test gaskets.

4.4 Support equipment, such as amplifiers, signal generators, and transmitting antennas should be located outside the shielded enclosure. The spectrum analyzer and receive antenna are located inside the shielded enclosure. The transmitting and receiving antenna distances should be 1 meter from the test plate on each side (2 meters plus the thickness of the test panel apart), which is a modification of the requirements of MIL-STD-285.

4.5 Table 1 lists typical equipment which can be used for this type of test. Due to factors such as rotation within the calibration cycle, repairs, out of service equipment, and dynamic range considerations, any of the equipment listed

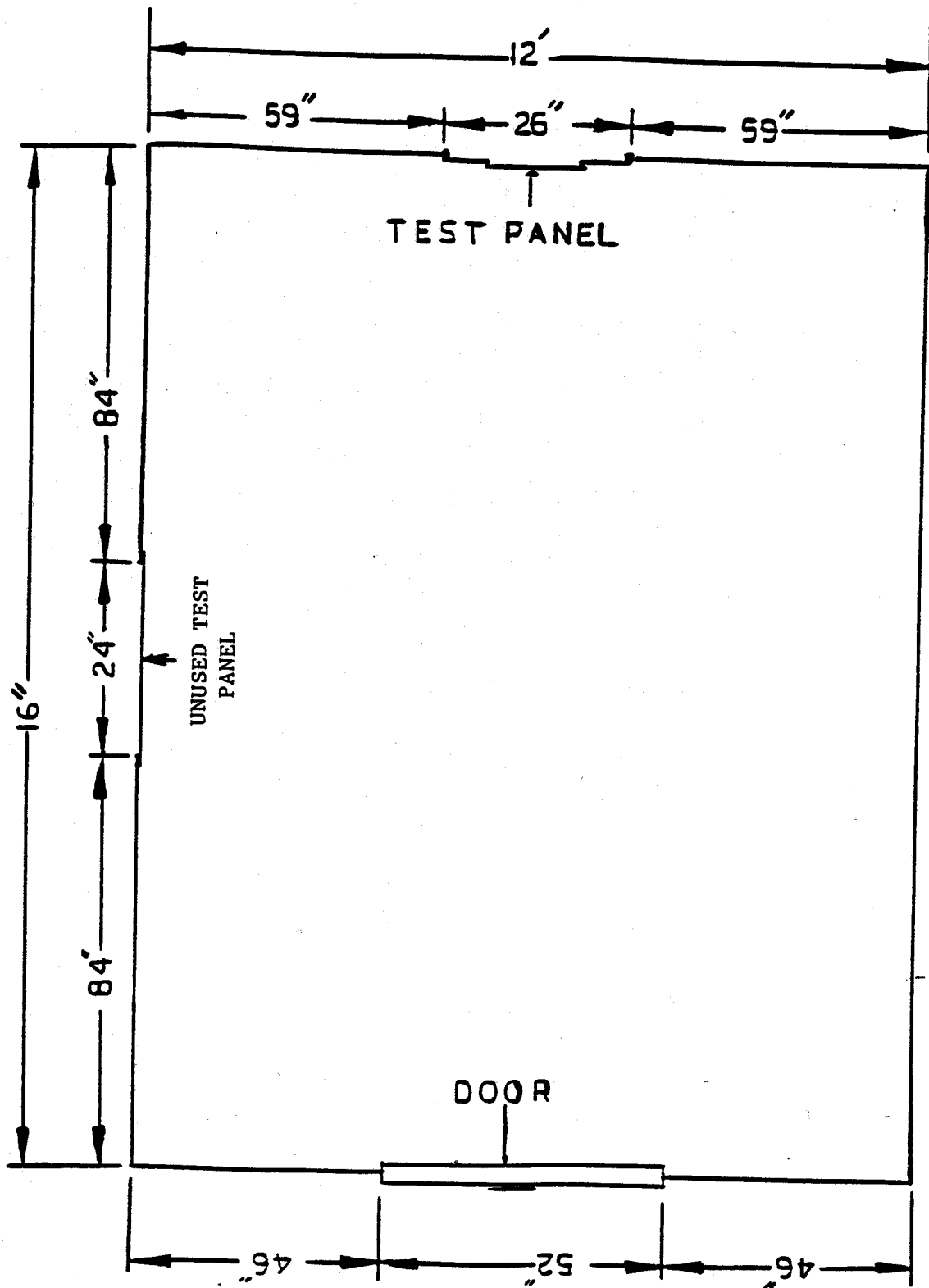

Figure 1
Test Enclosure Example

TEST EQUIPMENT		
MANUFACTURER	MODEL #	DESCRIPTION
H/P	8566B	Spectrum Analyzer
H/P	85685A	RF Preselector
Tektronix	496	Spectrum Analyzer
H/P	182T	Main Frame
H/P	8558B	Spectrum Analyzer Plug-In
H/P	8559A	Spectrum Analyzer Plug-In
H/P	645A	Signal Generator
H/P	8640B	Signal Generator
H/P	8672A	Signal Generator
EMCO	3105	Horn Antenna
EMCO	3109	Biconical Antenna
EMCO	3107	Parallel Element Antenna
Singer	CLS-105A	Log Spiral Antenna
Valhalla	4100ATC	Milli Ohm Meter
ENI	603L	RF Amplifier
RF Power Labs	220-IK60L	RF Amplifier
Solar	6552-1A	Audio Amplifier
Logimetrics	A300L	TWT RF Amplifier
Logimetrics	300XU	TWT RF Amplifier
Logimetrics	A300/S-08	TWT RF Amplifier
Logimetrics	300/C-08	TWT RF Amplifier
Narda	768-20	Attenuator
Solar	N/A	Audio Transformer
AllTrade	N/A	Socket Torque Drive

Table 1
Test Equipment

within this table may be substituted for another piece of equipment of similar function. A detailed list of the exact equipment used and calibration information will be noted in the test report. If attenuators are determined to be necessary at the time of test, their location within the test setup and value will be noted on the test data sheet and within the test report.

5.0 SHIELDING EFFECTIVENESS MEASUREMENTS

5.1 Each gasket material to be tested should be mounted (one at a time) in the groove of the 26 inch square aluminum test plate. The test plate is then placed over the open 24 inch square brass test fixture, which is welded to the wall of the shielded enclosure. The mounting bolts (fasteners) should be non-conductive plastic. These fasteners should be tightened as much as possible without stripping or breaking. Each gasket tested will be deflected properly, as controlled by the Lexan compression stop affixed to the aluminum test plate (see Figure 2).

5.2 The test should be performed at frequencies of 20 MHz, 40 MHz, 60 MHz, 80 MHz, 100 MHz, 200 MHz, 400 MHz, 600 MHz, 800 MHz, 1000 MHz, 2000 MHz, 4000 MHz, 6000 MHz, 8000 MHz, and 10,000 MHz. The type of field (i.e., electric or plane wave), and the antenna polarization, should be noted on the test data sheet for each frequency under investigation.

5.3 Due to the symmetrical nature of the test setup and fixtures, only one antenna polarization is required during testing.

5.4 Three different values of shielding effectiveness can be obtained, based on three different initial reference measurements. This allows a variation in interpretation of the data, and some flexibility in adapting these measurements to actual applications. The three different references allow an evaluation of the attenuation effect of the aperture size and cover presence. The references taken should be as follows:

A. Reference signal measurement A is to be performed with the antennas in free space, strictly in accordance with the requirements of MIL-STD-285, except as noted in Paragraph 4.4 (see Figure 3).

B. Reference signal measurement B is to be performed through the 24 inch x 24 inch opening, with the antennas located in the same position as the final testing, but with no cover plate over the open aperture. This reference measurement technique is in accordance with the requirements of MIL-G-83528B (see Figure 4).

C. Reference signal measurement C is performed through the 24 inch x 24 inch opening covered with the aluminum plate in the same position as the final testing, but with no gasket in place. This is accomplished by mounting the plate to the enclosure (brass frame) with the non-conductive fasteners, as in the final tests. The non-conductive compression stop affixed to the test plate creates the proper separation (see Figure 5).

5.5 Final signal measurements with the gasketed panel in place are to be performed as illustrated on Figure 6.

5.6 The shielding effectiveness is calculated by taking the power level recorded during the reference measurement, and subtracting from it the power level recorded during measurements made with the gasketed plate covering the aperture. Below is a sample calculation.

5.7	Reference	-	Gasketed Panel	=	Shielding Effectiveness
	Level		Level		
	+10 dBm	-	(-102 dBm)	=	112 dB

5.8 These calculations can be made utilizing any one of the three reference measurements outlined in Paragraph 5.4 above. Calculations utilizing Reference B are required. Calculations utilizing References A and C can be made for informational purposes.

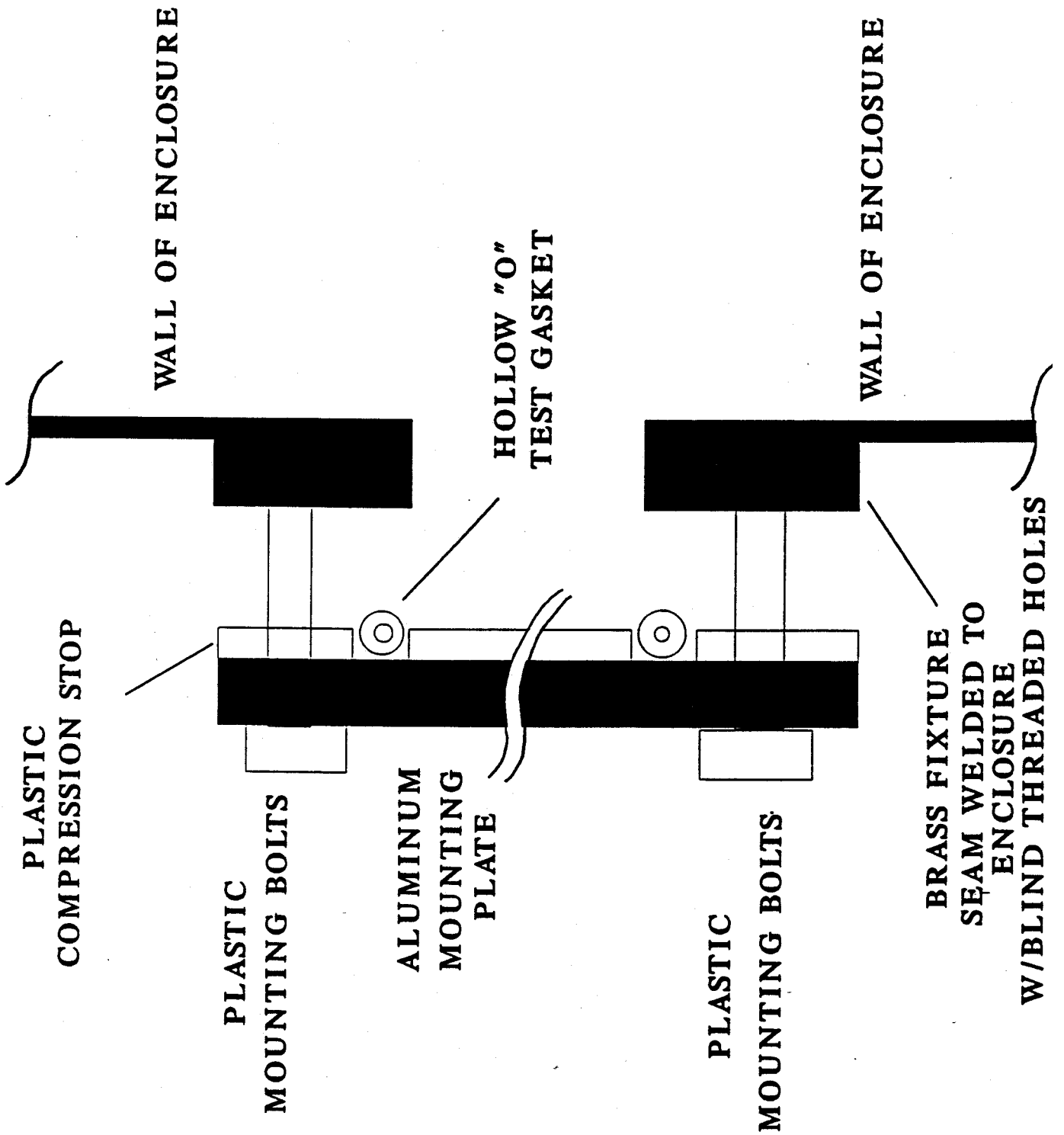

Figure 2
Setup Cross-Section

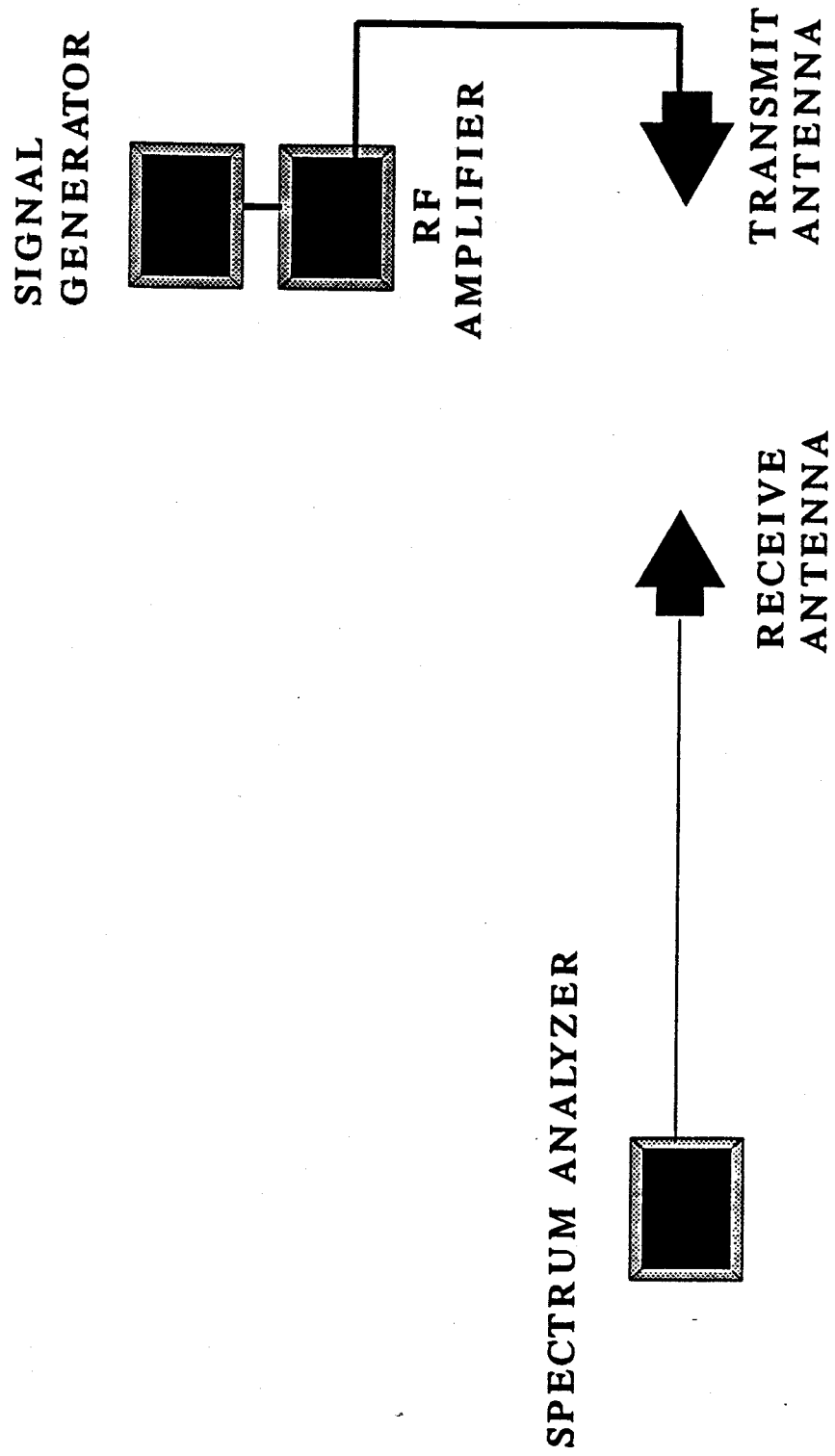

Figure 3
Reference Measurement A

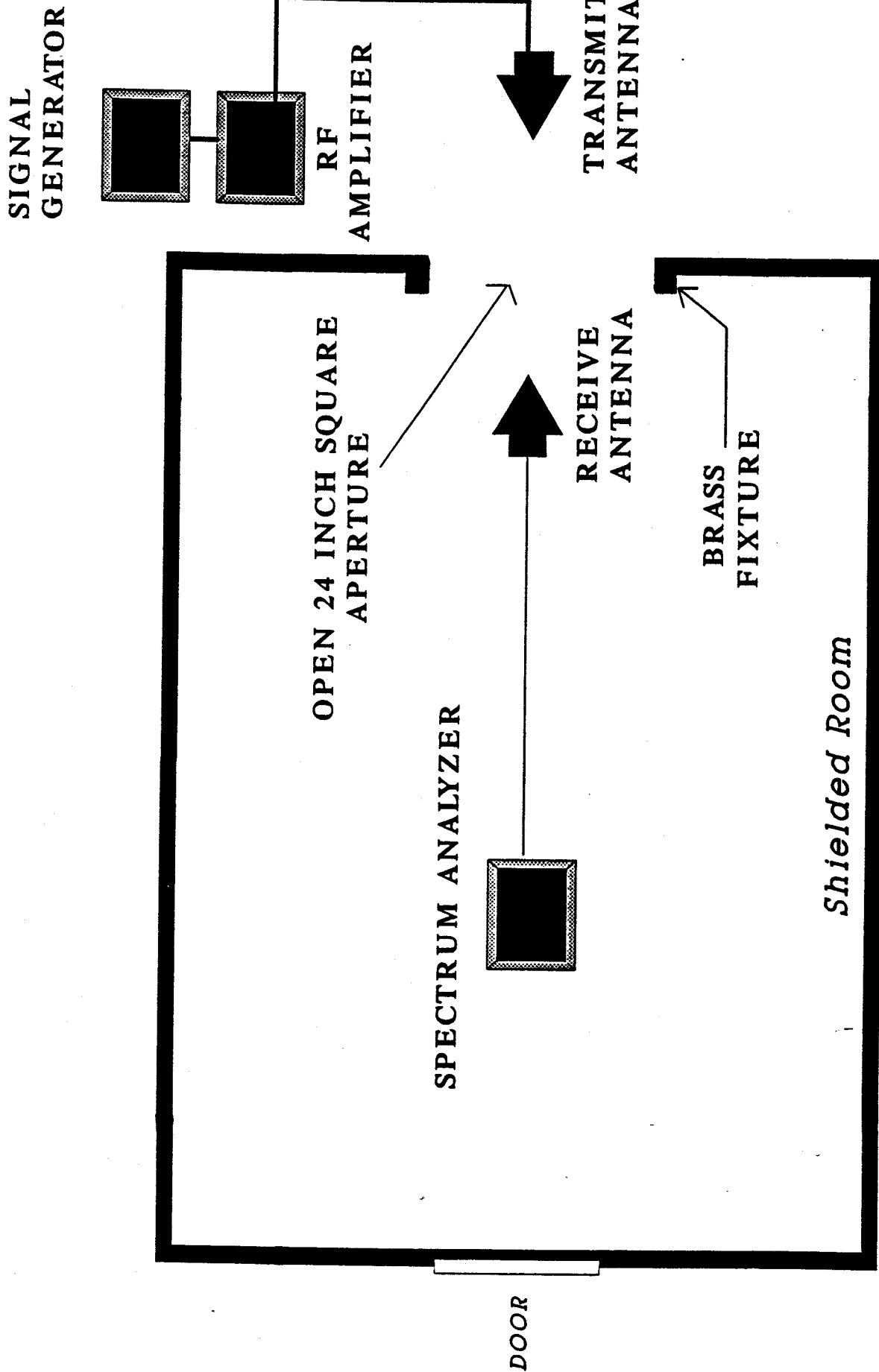

Figure 4
Reference Measurement B

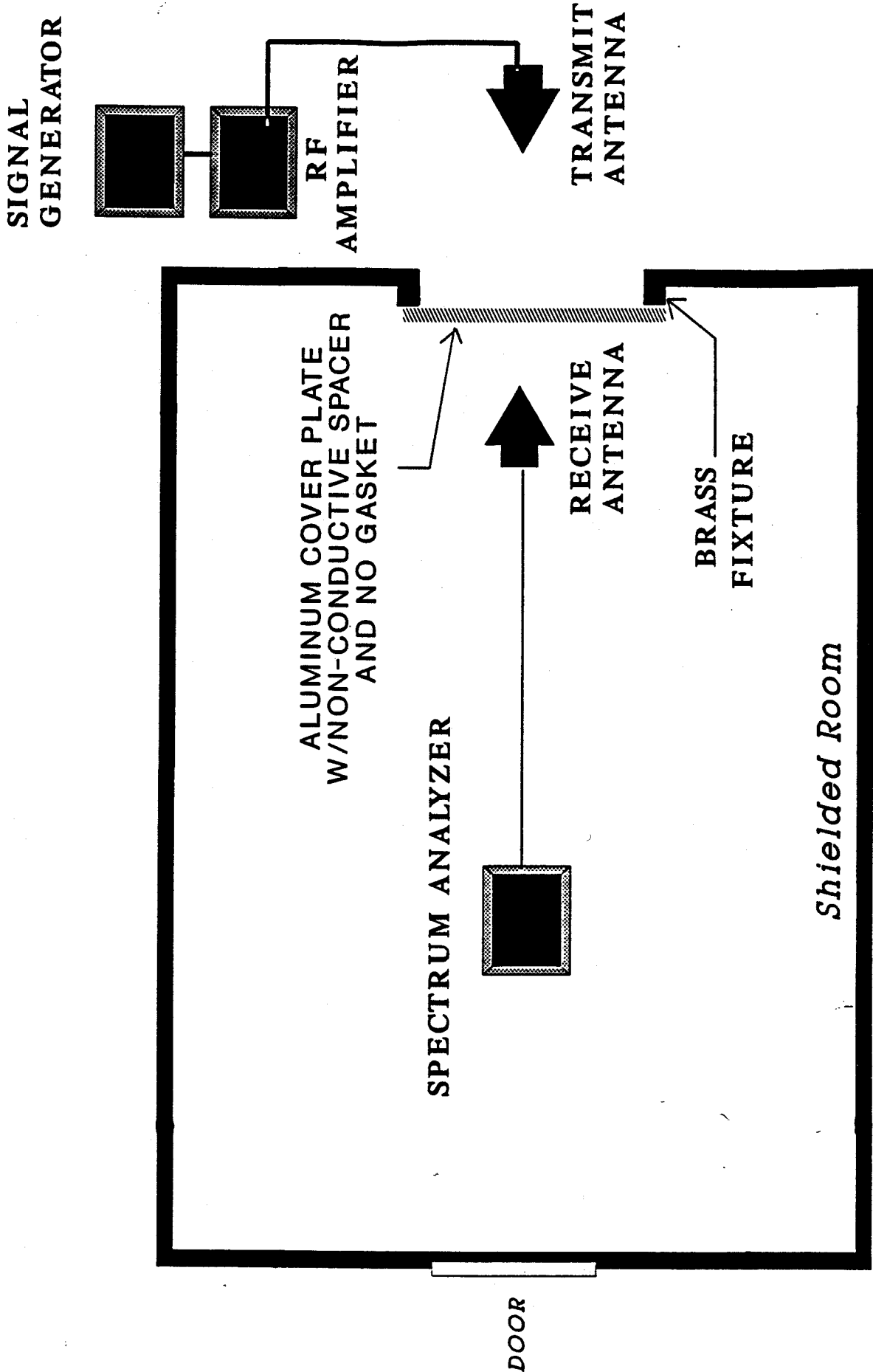

Figure 5
Reference Measurement C

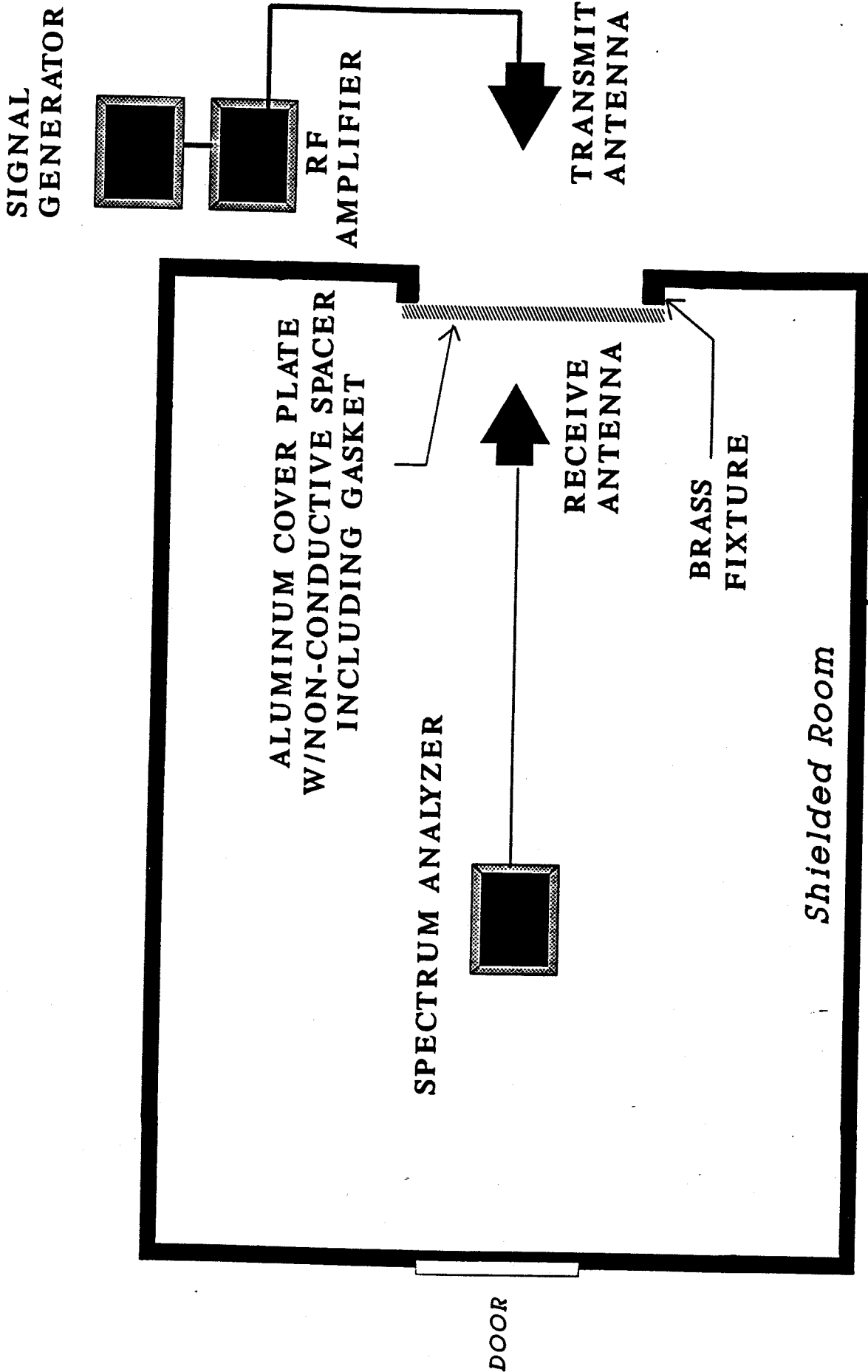

Figure 6
Final Gasketed Panel Measurement Setup

6.0 VOLUME RESISTIVITY MEASUREMENTS

6.1 For conductive elastomer gaskets, DC volume resistivity measurements are useful in helping to interpret shielding effectiveness data.

6.2 Resistance measurements of the conductive gaskets should be made using the surface probe method of CEPS-0002 (Ref. Section 2.2). The surface probe electrode should be placed on the gasket as illustrated in Figure 7. Calculate the volume resistivity of the gasket from:

$$VR = (R \times CS)/L$$

Where VR = DC volume resistivity in Ω -cm

R = measured resistance in Ω

CS = gasket cross-sectional area in square cm

L = 2.54 cm (distance between probe electrodes)

6.3 The measured resistance and calculated volume resistivity should be recorded at several points along the conductive gasket strip.

7.0 THROUGH RESISTANCE MEASUREMENTS

7.1 DC through resistance electrical measurements are useful in helping to interpret the shielding effectiveness data.

7.2 Gasket resistance measurements should be made using a variety of flange materials or coated/plated disks. These disks are 3 inches in diameter and 1/4 inch thick, as illustrated on Figure 8.

7.3 The following test disk sets should be prepared for through resistance measurements on the gasket materials:

- A. Two aluminum disks
- B. One aluminum and one brass disk
- C. Two brass disks
- D. Two steel disks
- E. Two aluminum disks, gold plated
- F. Two aluminum disks, MIL-C-5541 Class 3 conversion coated
- G. Two aluminum disks, chrome plated

7.4 Through resistance measurements should

be made for each set of test disks listed above, using two samples of each gasket material 2.5 inches in length each. The two lengths of gasket material should be placed between the two disks of each set and deflected the same amount as provided in the shielding effectiveness test by the appropriate compression stop described in paragraph 4.1.2.

Proper deflection is controlled by the use of plastic (non-conductive) shim stock. Non-conductive plastic bolts can be used to hold the disks together while making the measurements.

7.5 Through resistance measurements shall be performed as illustrated on Figure 9.

7.6 When a variation in conductivity is found during DC Volume Resistivity measurements described in Section 6 above, the through resistance should also be measured and recorded for several different places along the gasket length. All values recorded should be averaged.

8.0 TEST REPORT

8.1 Detailed test data sheets are to be inserted into the test report. The test data sheets will include the test results, the name of the person who performed the test, and the location and time of the test. Refer to Table 2 for an example of the test data sheet.

8.2 Any deviation from the test plan or MIL-STD-285 should be noted on the test data sheet and within the test report. A full explanation of the deviation and the corrective action taken should also be provided on the test data and in the test report.

8.3 The three sets of reference measurements should be recorded on the data sheets and included within the test report.

8.4 Three different sets of shielding effectiveness values can be calculated based on the three reference measurements. This will allow a variation in interpretation of the data.

8.5 This test method can be used to correlate shielding effectiveness versus volume resistivity, and shielding effectiveness versus through conductivity.

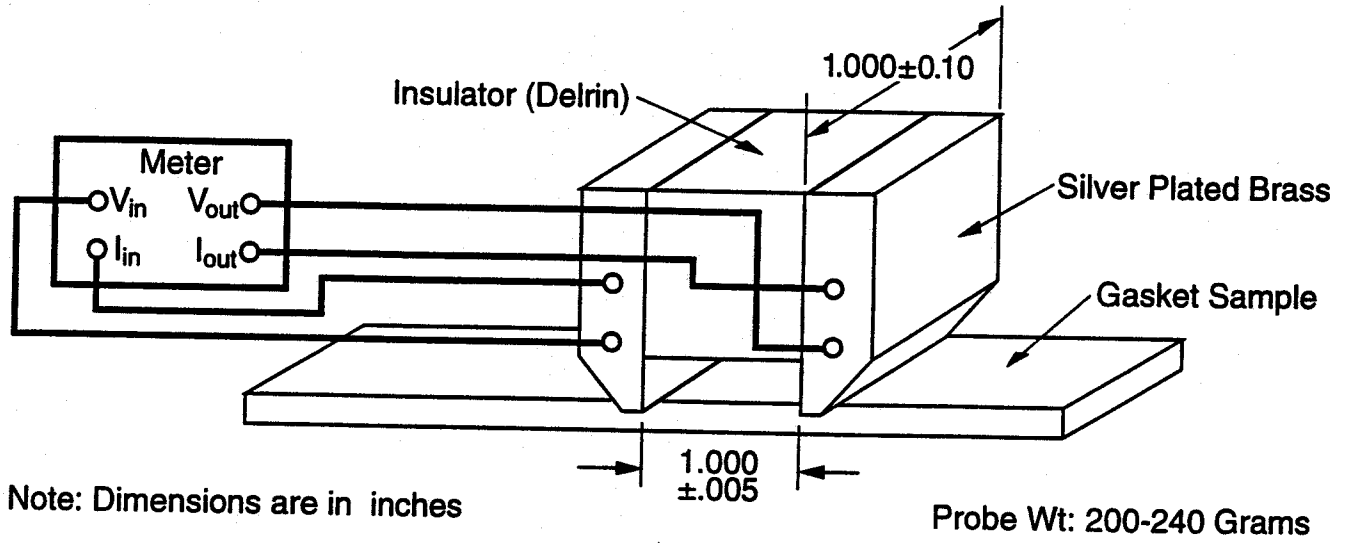
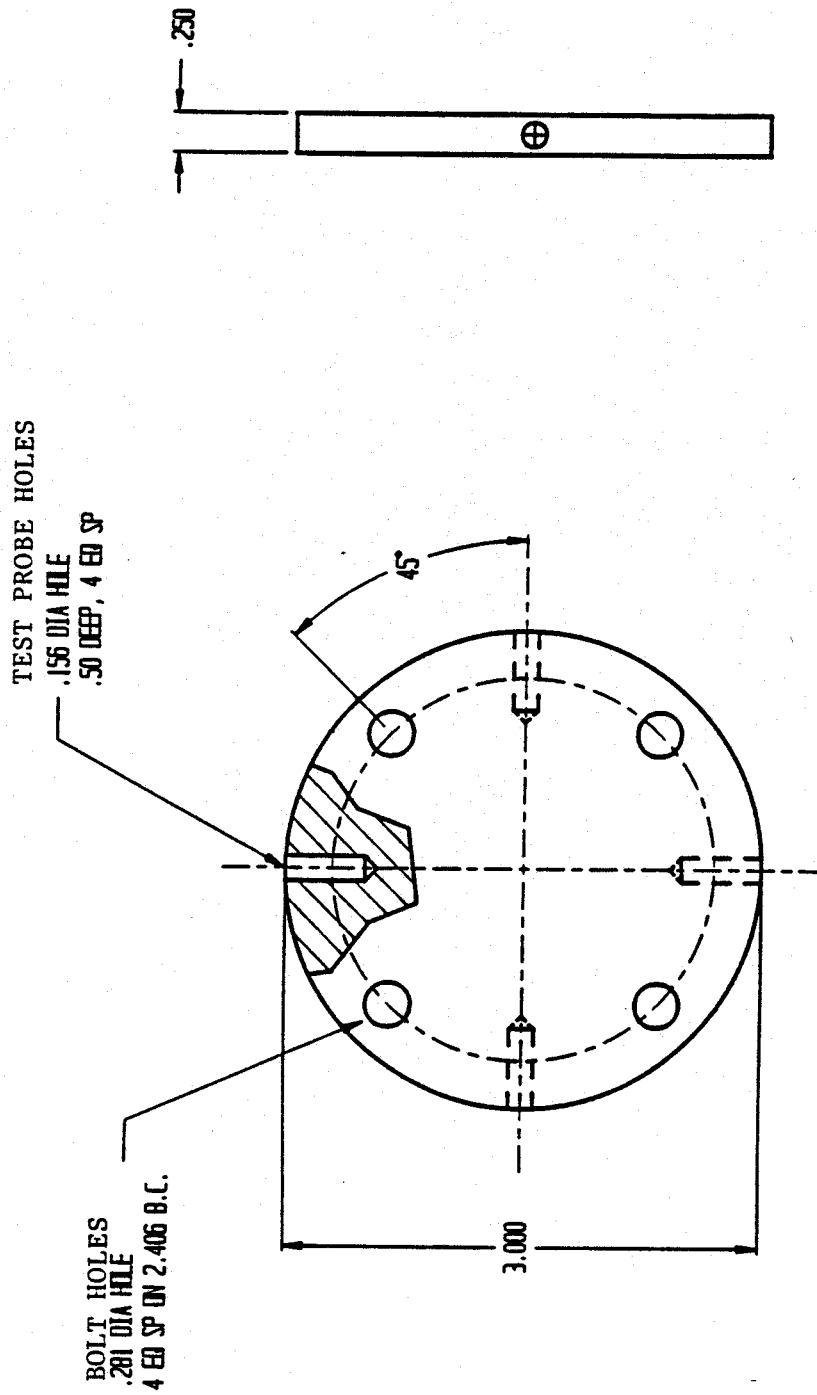

Figure 7
Volume Resistivity Test Procedure



Dimensions in inches

Figure 8
Through Resistance Test Disks
(Two needed per set)

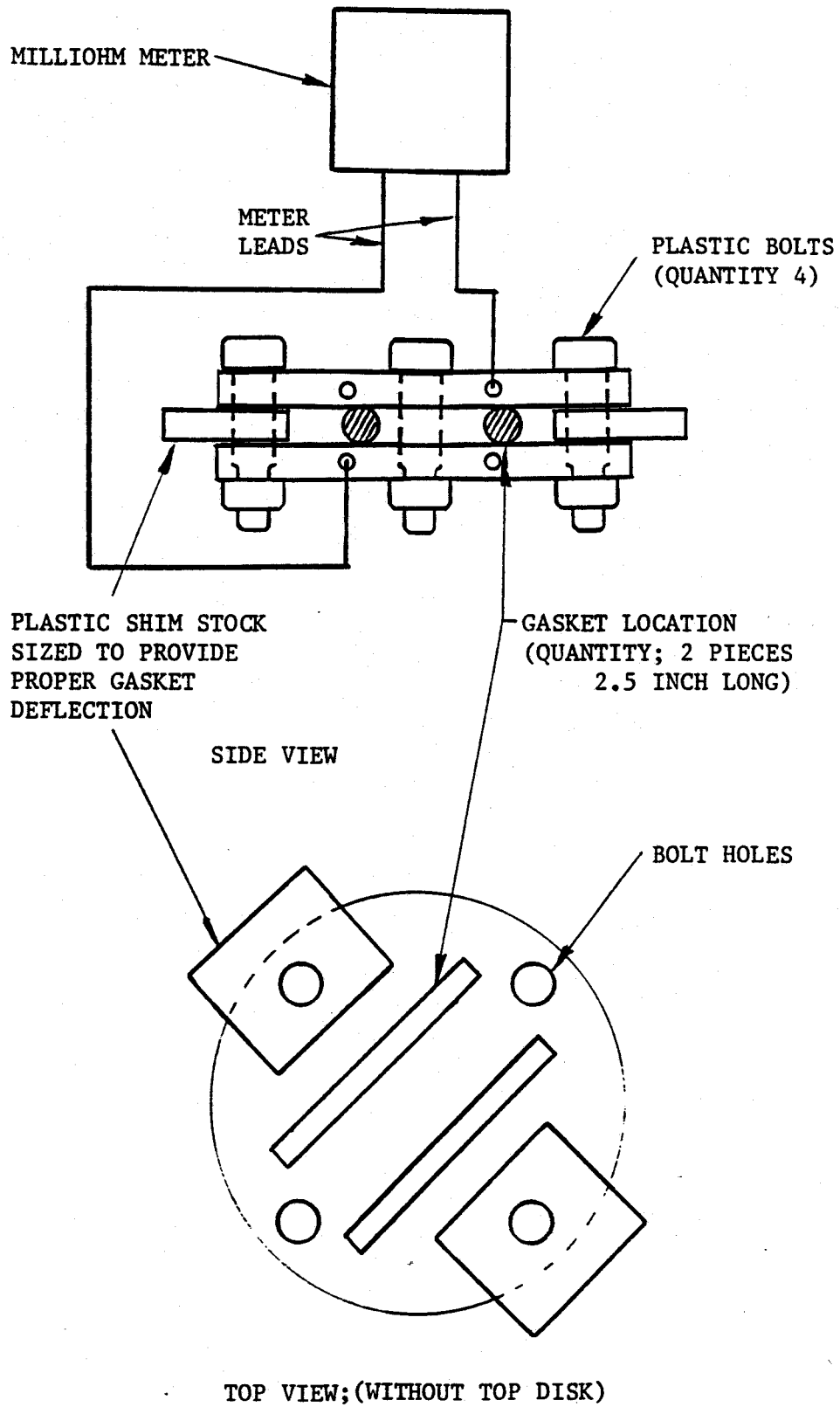

Figure 9
Through Resistance Measurement Setup

Appendix

Drawings 1A through 7B

Section 2

CHOMERICS 

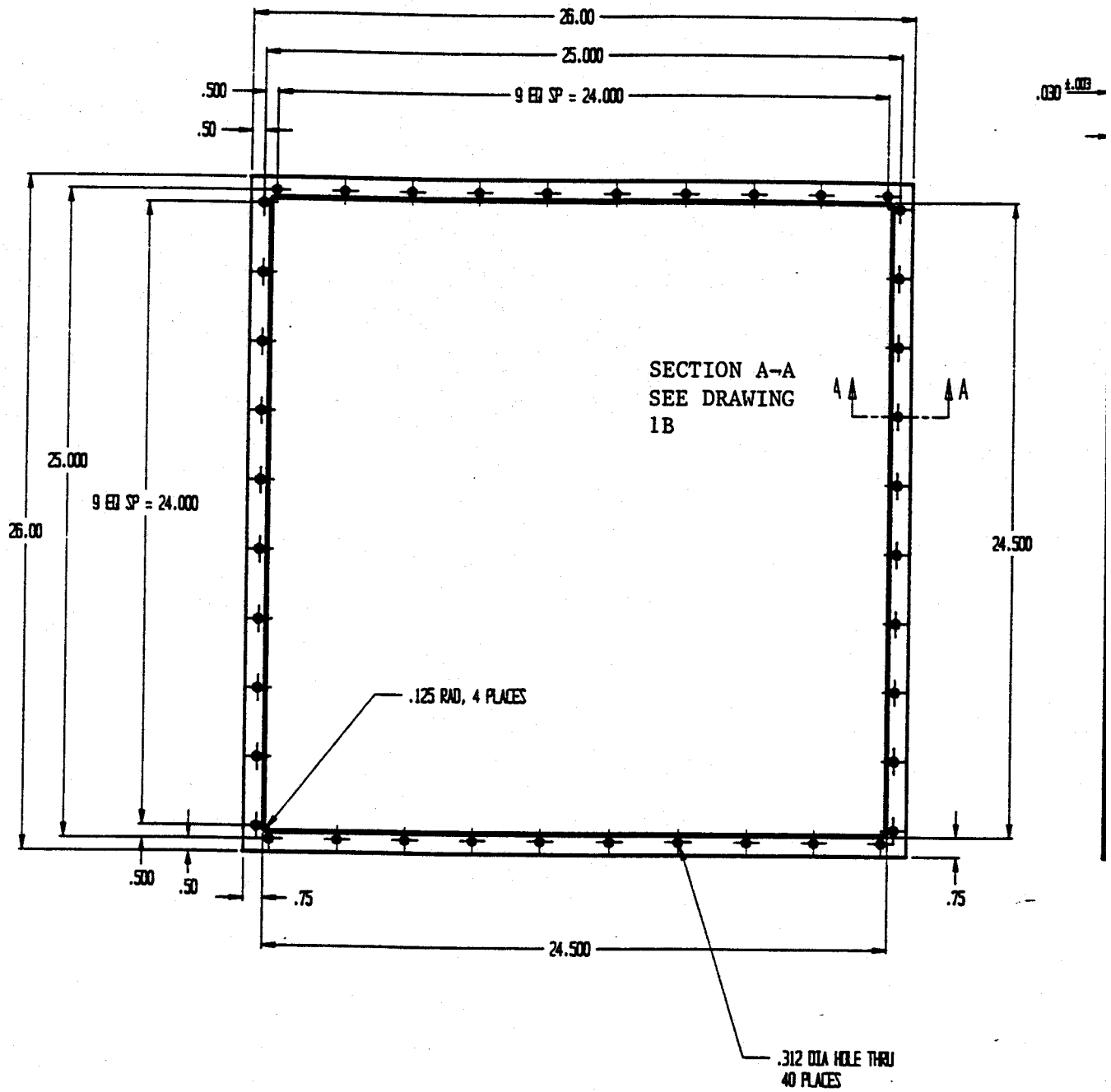

ALR-93-014-1
 p/n 10-04-2561-XXXX (Solid "O" Extrusion)
 0.062" Diameter

Drawing 1A

A-1

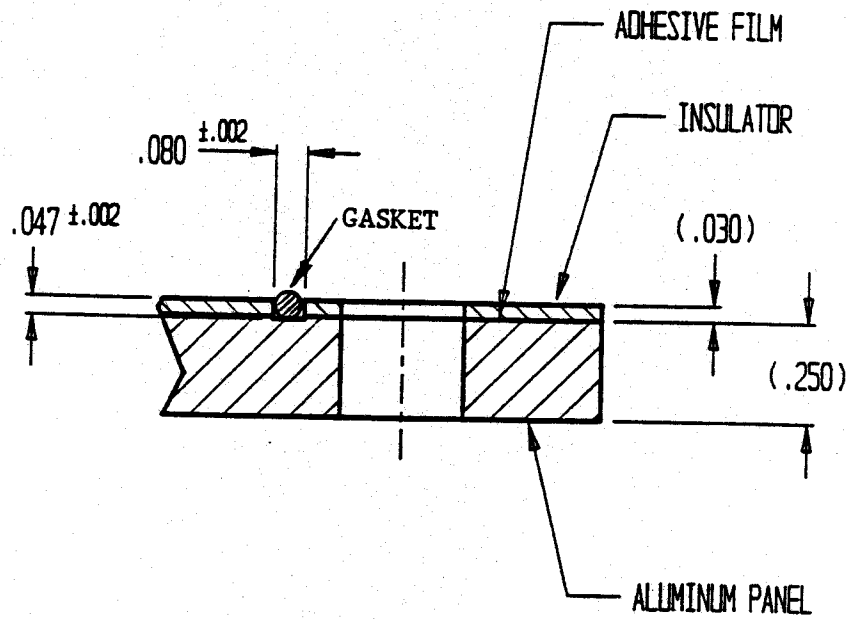

SECTION A-A
SCALE: 2X

ALR-93-014-1
P/N 10-04-2561-XXXX (Solid "O" Extrusion)
0.062" Diameter

Drawing 1B

A-2

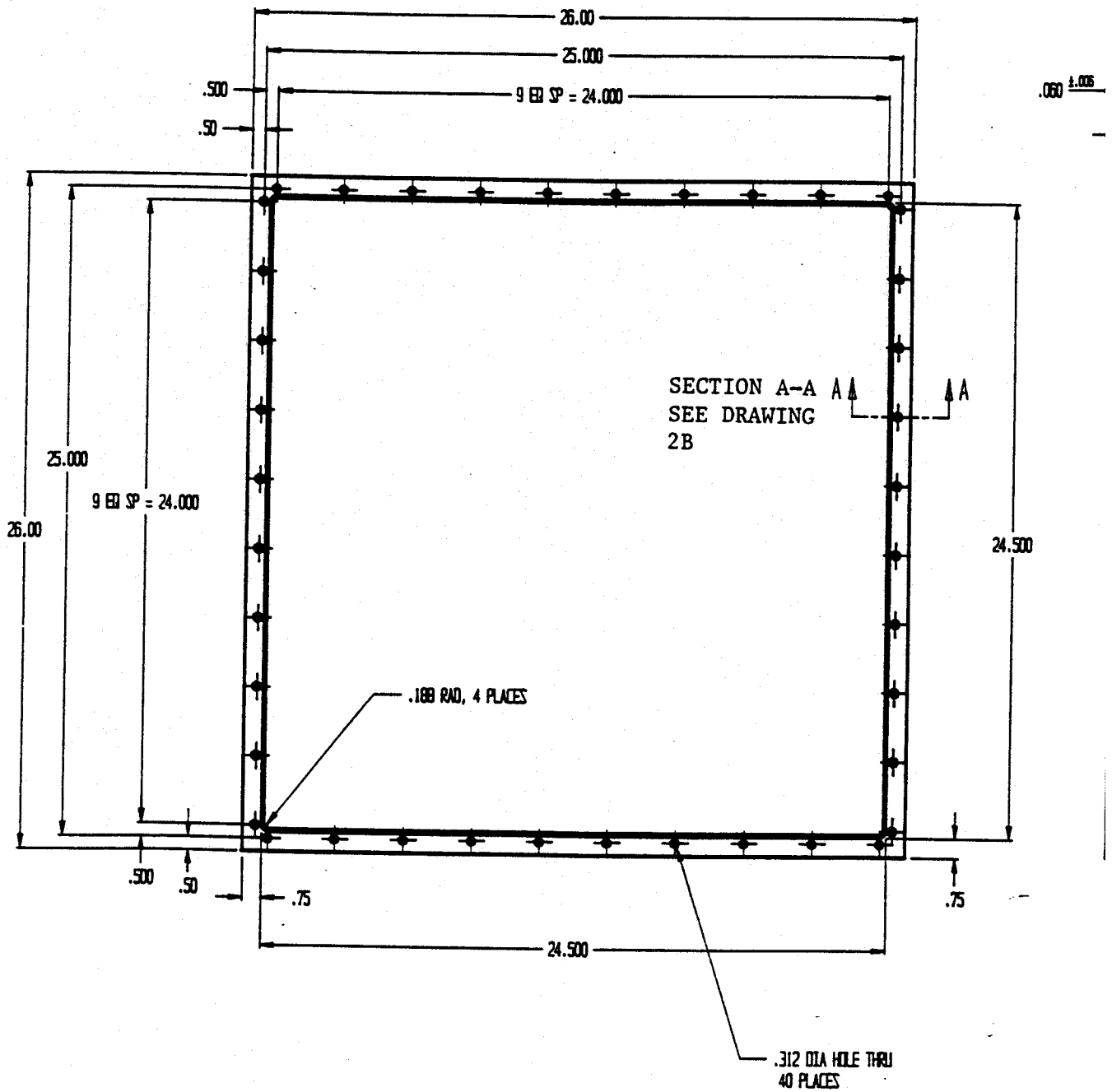

ALR-93-014-2
 P/N 10-04-2865-XXXX (Solid "O" Extrusion)
 0.093" Diameter

Drawing 2A

A-3

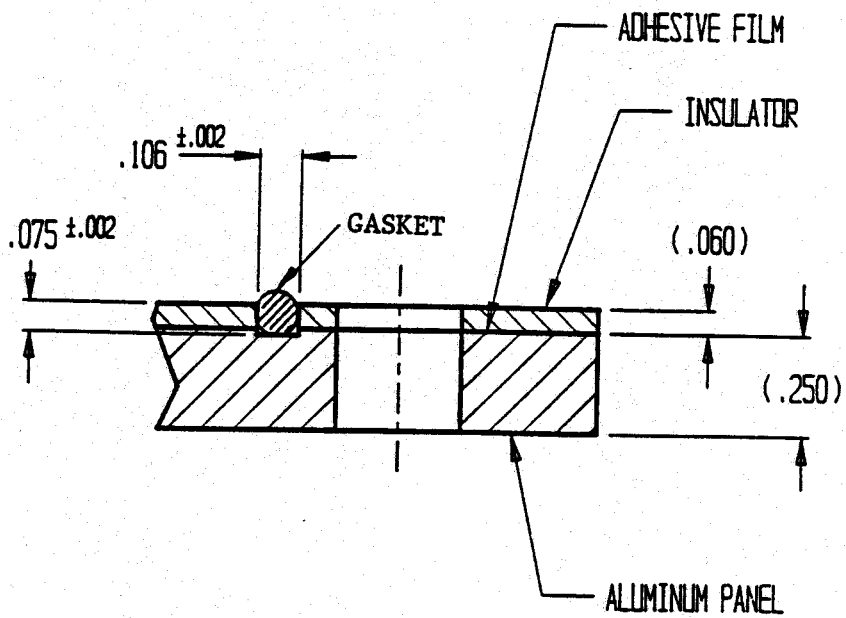

SECTION A-A
SCALE: 2X

ALR-93-014-2
 P/N 10-04-2865-XXXX (Solid "O" Extrusion)
 0.093" Diameter

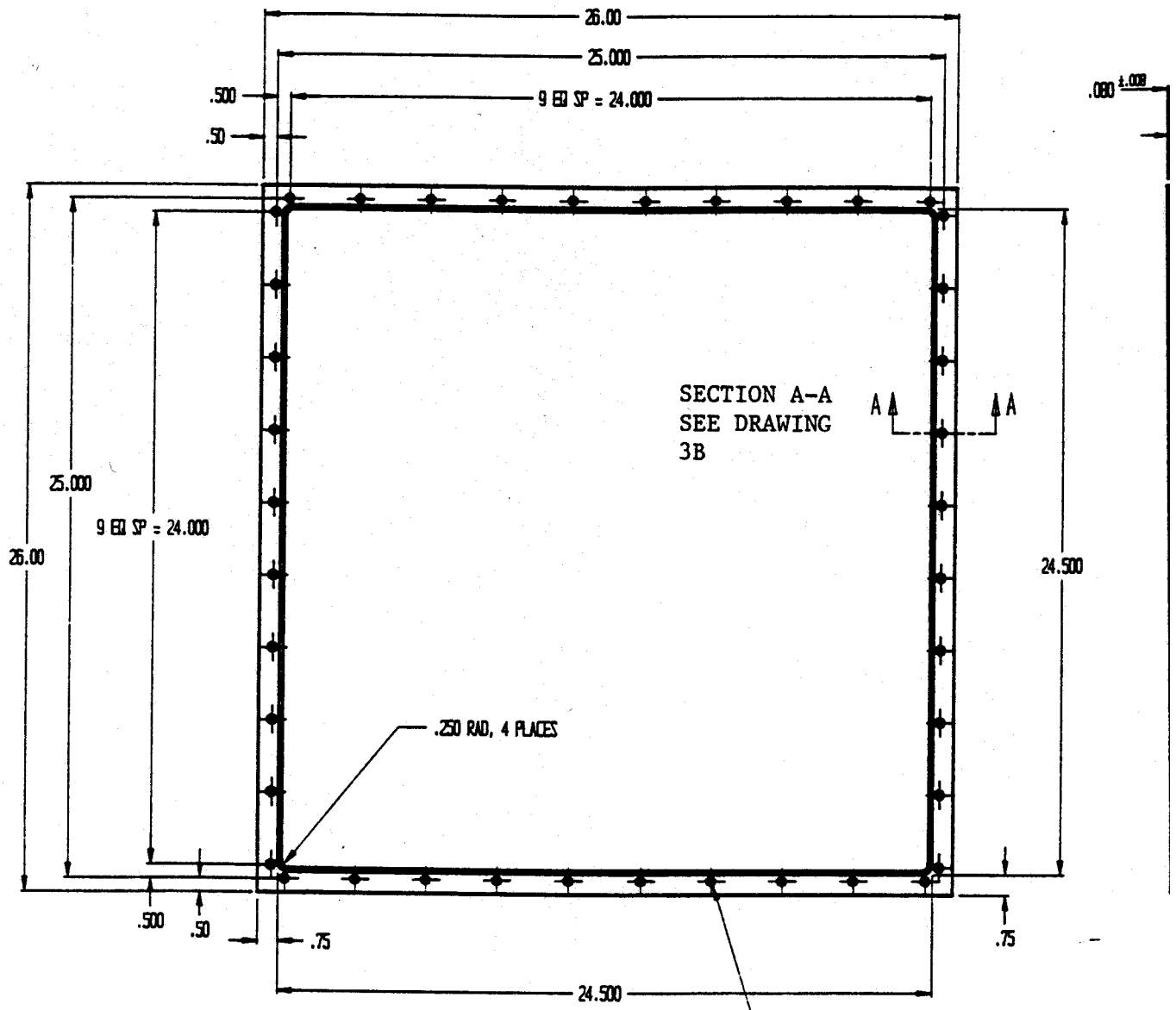

ALR-93-014-3
 P/N 10-04-2463-XXXX (Solid "O"
 Extrusion)
 0.125" Diameter

.312 DIA HOLE THRU
 40 PLACES

Drawing 3A
 A-5

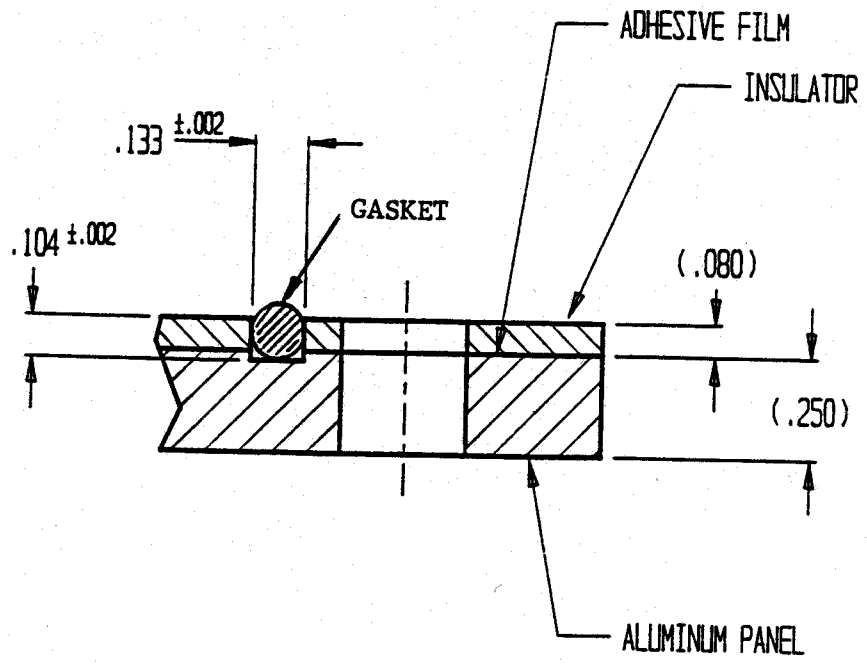

SECTION A-A
SCALE: 2X

ALR-93-014-3
P/N 10-04-2463-XXXX(Solid "O" Extrusion)
0.125" Diameter

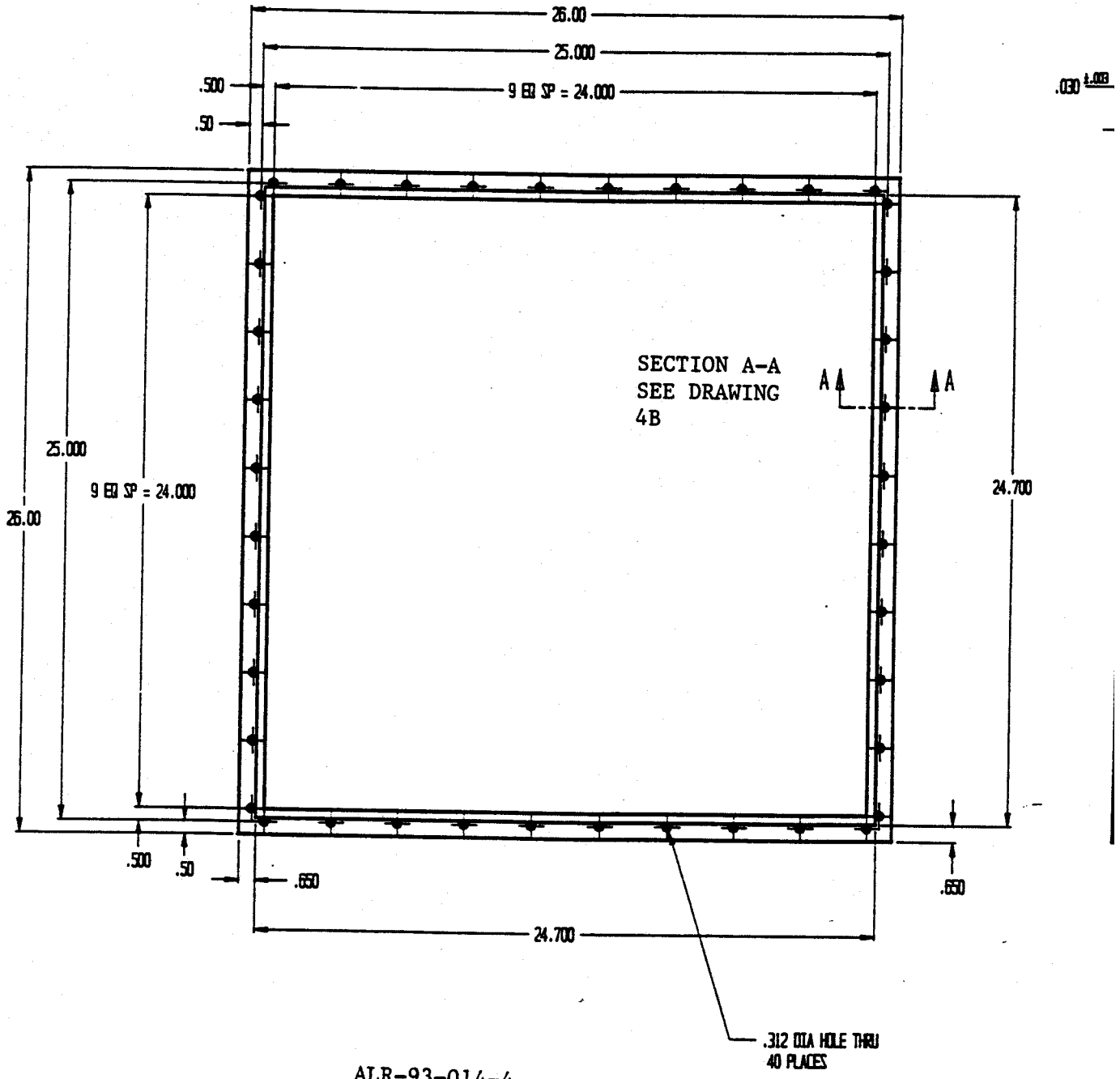

ALR-93-014-4
 P/N 10-07-3226-XXXX (Rectangular Strip Extrusion)
 0.062" Thick X 0.250" Wide

Drawing 4A
 A-7

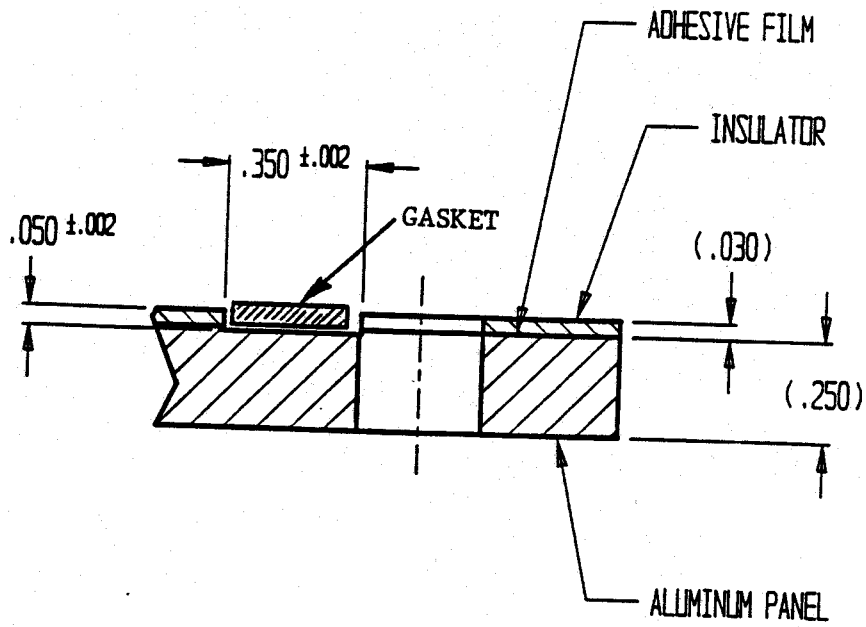

SECTION A-A
SCALE: 2X

ALR-93-014-4
P/N 10-07-3226-XXXX (Rectangular Strip Extrusion)
0.062" Thick X 0.250" Wide

Drawing 4B
A-8

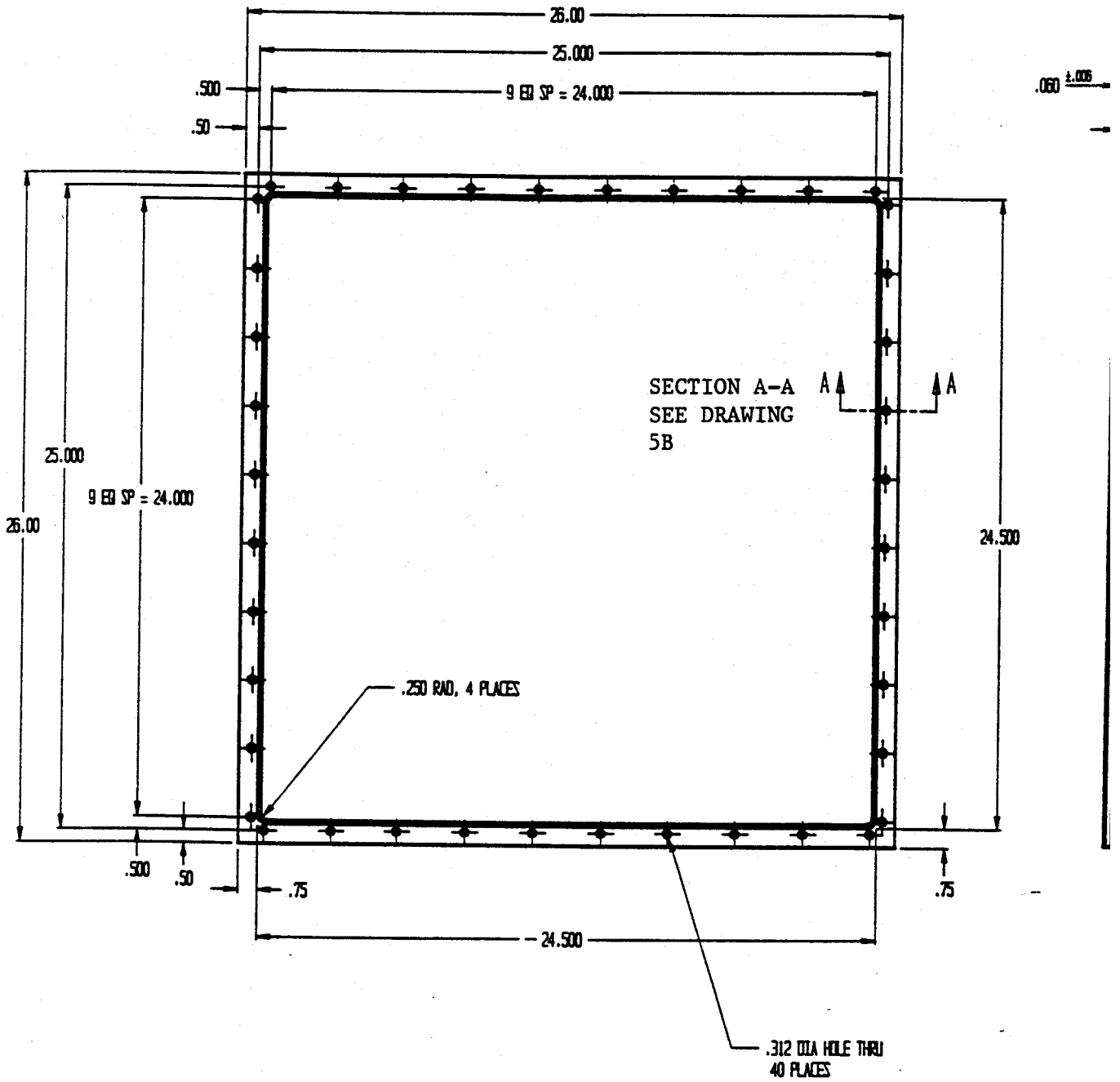

ALR-93-014-5
 P/N 10-04-2999-XXXX (Hollow "O" Extrusion)
 0.125" O.D X 0.062" I.D.

Drawing 5A

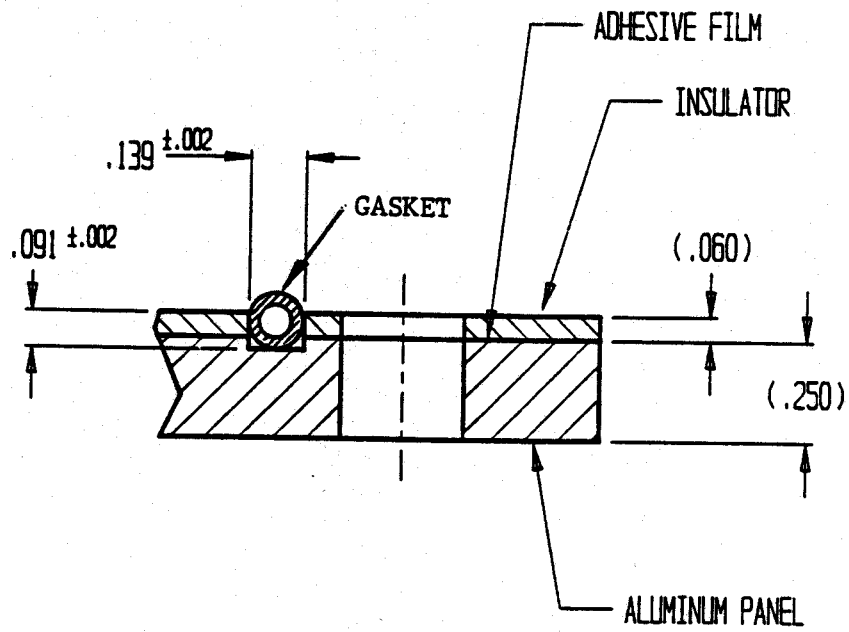

SECTION A-A

SCALE: 2X

ALR-93-014-5
 P/N 10-04-2999-XXXX (Hollow "O" Extrusion)
 0.125" Q.D. X 0.062" I.D.

Drawing 5B

A-10

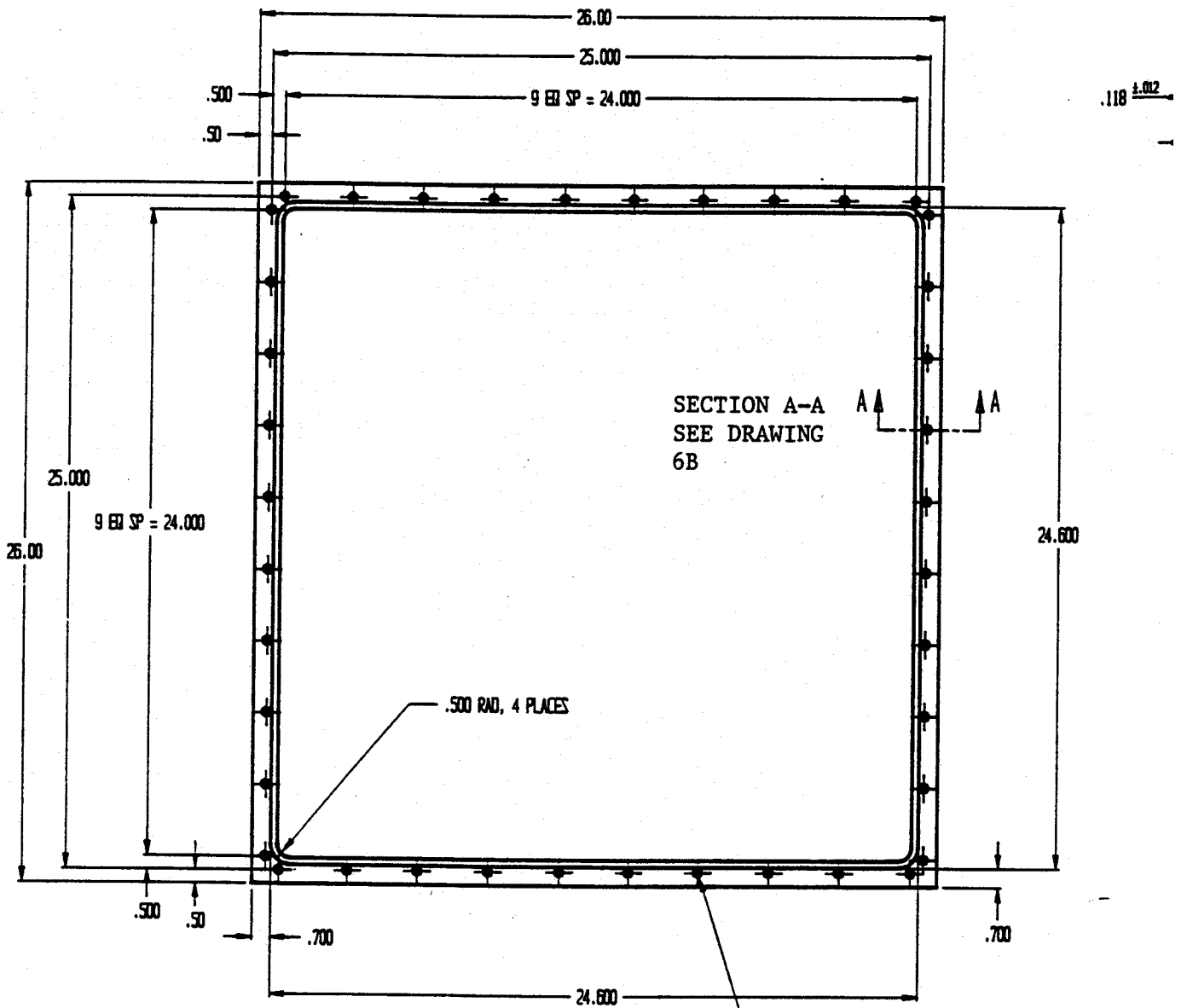

ALR-93-014-6
 P/N 10-04-2737-XXXX (Hollow "O"
 Extrusion)
 0.250" O.D. X 0.125" I.D.

Drawing 6A

A-11

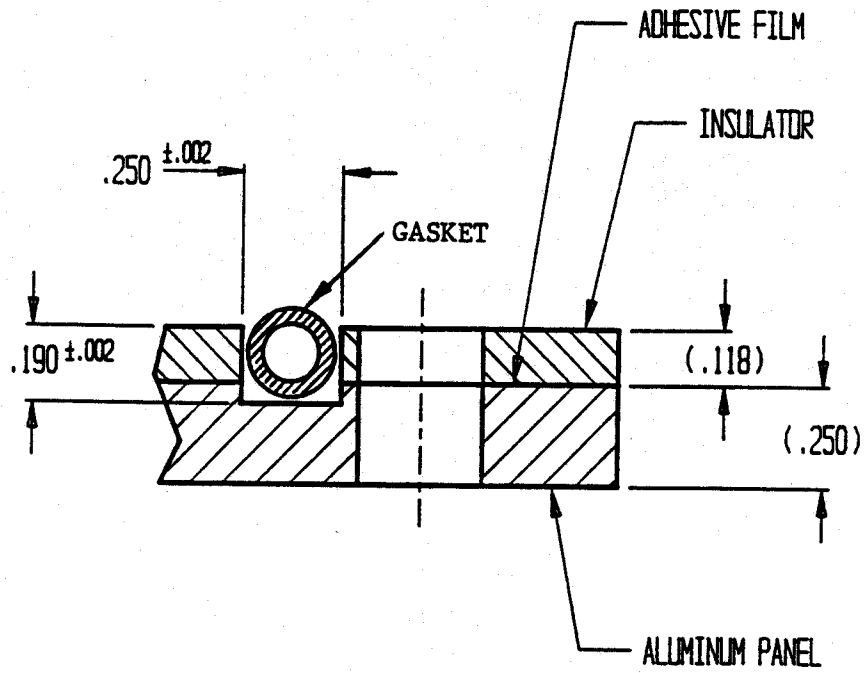

SECTION A-A
SCALE: 2X

ALR-93-014-6
P/N 10-04-2737-XXXX (Hollow "O" Extrusion)
0.250" O.D. X 0.125" I.D.

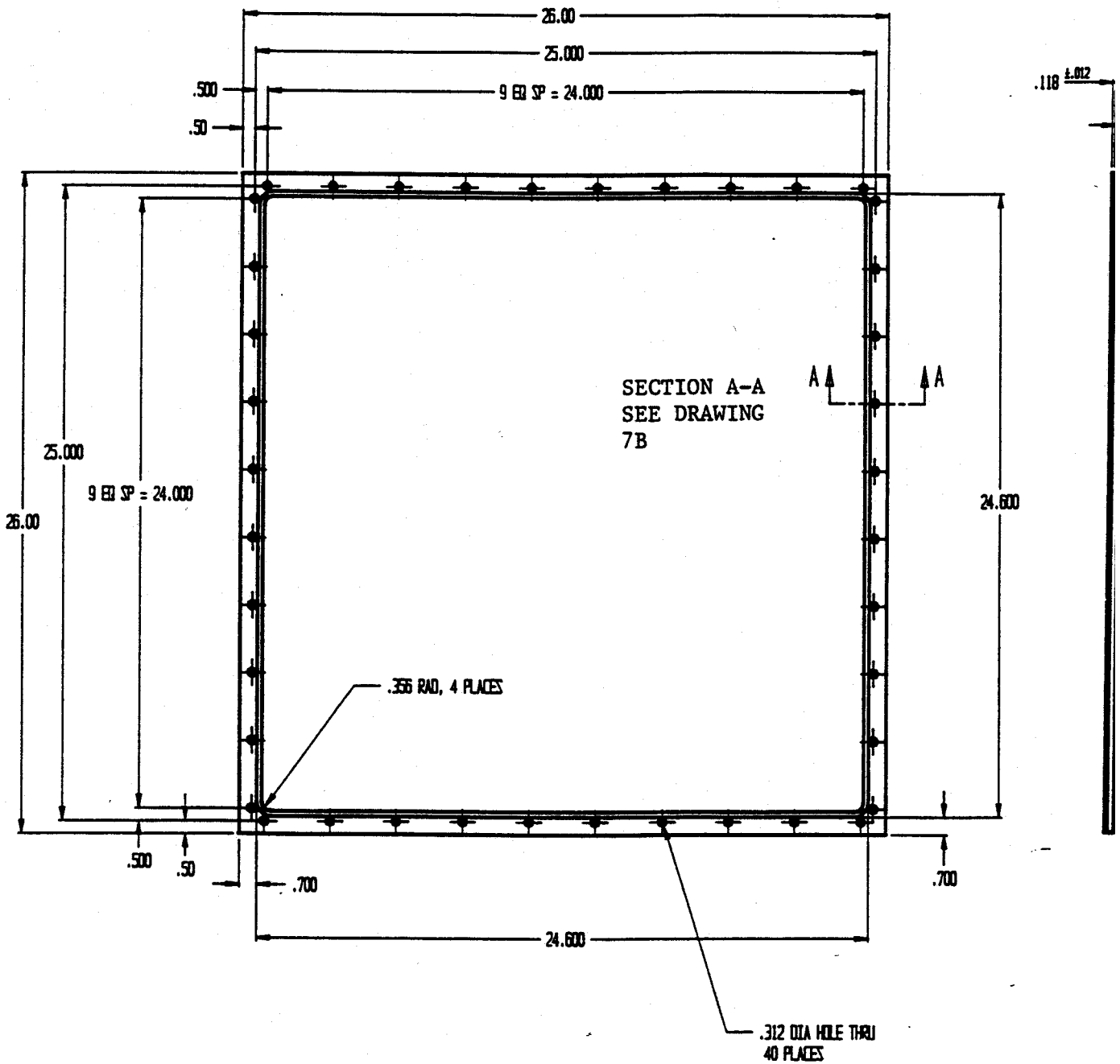

ALR-93-014-7
 P/N 10-05-1577-XXXX (Solid "D" Extrusion)
 .0175" High X 0.178" Wide

Drawing 7A

A-13

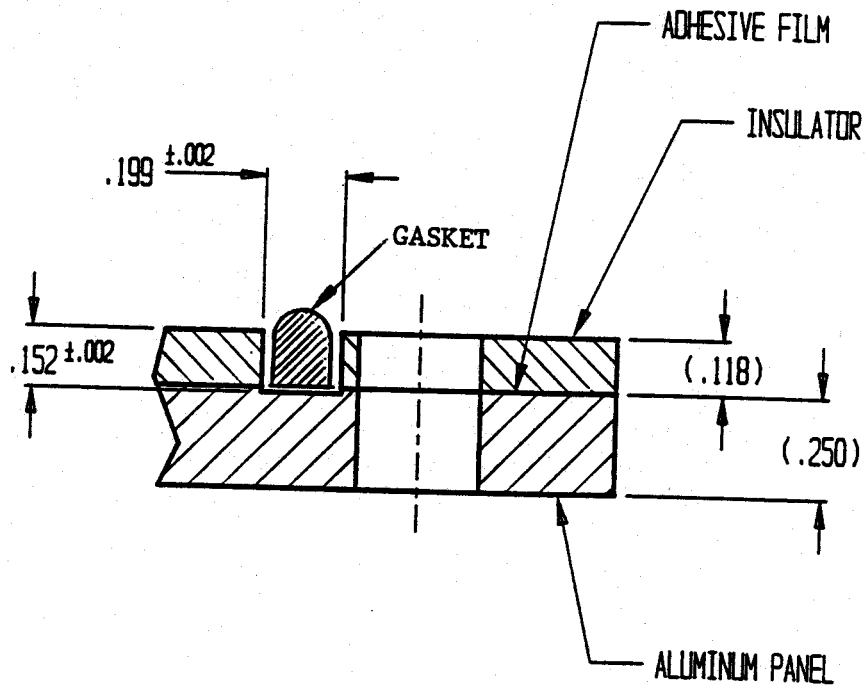

SECTION A-A
SCALE: 2X

ALR-93-014-7
 P/N 10-05-1577-XXXX (Solid "D" Extrusion)
 0.175" High X 0.178" Wide

Drawing 7B

A-14