

Molded-In-Place Cover Seals

Complete gasket/cover assemblies to customer specification offer optimized shielding and economies of manufacture, installation and maintenance

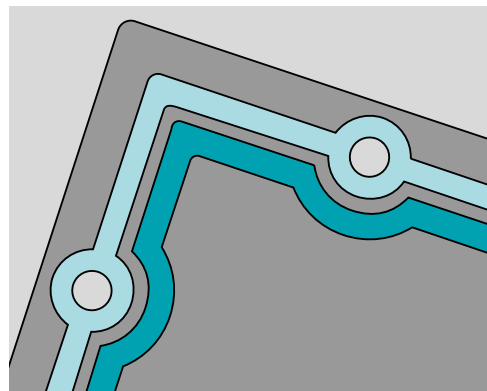
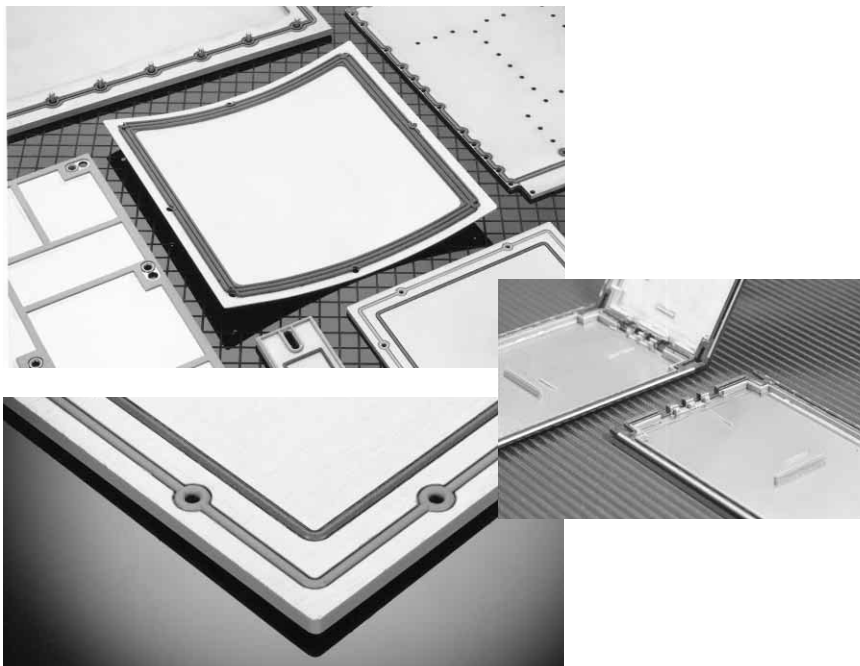

Molding a non-conductive elastomer to the outboard edge and around bolt holes further protects the inboard conductive elastomer and the enclosure in corrosive environments.

Molded-In-Place Cover Seals

For more than thirty years, Chomerics' conductive elastomer seals have been chosen for airborne, shipboard and ground-based electronics equipment to meet high levels of shielding and environmental sealing requirements. In hundreds of applications, we've molded the conductive elastomer onto covers machined by Chomerics or provided by our customers, to create a permanent seal/cover assembly with significant shielding, installation and maintainability benefits.

Chomerics has in-house CNC machining capability, for fast, economical turn-around of prototypes, and developmental modifications of structural components, as well as full production capacity for components and seal assemblies. Incorporating our corrosion-resistant, silver-plated-aluminum filled silicones and fluoro-silicones, these assemblies are particularly suited to environmentally demanding military/aerospace applications.

Start with Superior Materials

Our corrosion-resistant CHO-SEAL® 1285 and 1298 silver/aluminum gasket materials provide 90dB of shielding effectiveness at 1 GHz, excellent salt-spray resistance (MIL-STD 810), EMP survivability and a -55° to 200°C use temperature range.

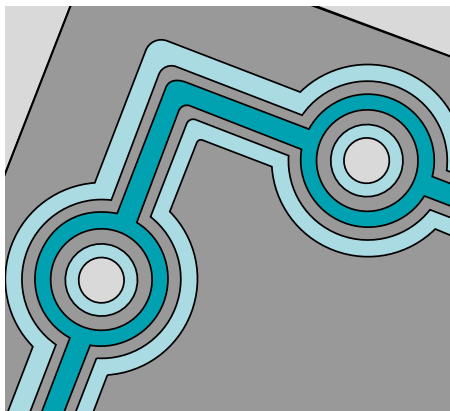

This gasket design provides the ultimate protection in harsh environments. A non-conductive elastomer is molded around the bolt holes, and *both* inboard and outboard of the conductive elastomer.

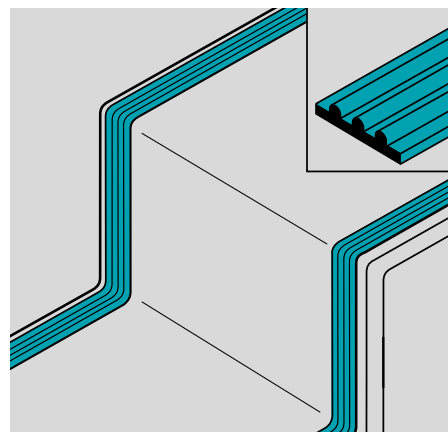

Installing conventional gaskets on enclosure covers with less than 90° bends is extremely difficult. Molding a gasket to this configuration is not only easier, but the elastomer cross section can be designed to provide maximum shielding with a lower closure force (*see inset*).

continued

Enclosure shielding and environmental sealing performance are improved in a number of ways when conductive elastomer gaskets are molded directly to a flange surface instead of being adhesive bonded or mechanically attached.

A Molded-In-Place gasket permits the optimum seal profile to be formed, achieving more gasket deflection with limited closure force when compared to flat, bonded gaskets. Eliminating the adhesive reduces interface resistance and maximizes shielding effectiveness. It also improves environmental sealing by eliminating the uncontrollable variations in adhesive thickness that often turn theoretically good designs into field failures.

Design and Cost Advantages

Molded-In-Place cover/gasket assemblies offer the following other advantages over extruded or die-cut gaskets:

- **Gasket Volume** – typically less seal material is needed compared to die-cut gaskets, thereby reducing costs in many applications.
- **Cross Section Design** – compression/deflection requirements can be met with fewer fasteners, resulting in improved maintainability.
- **Fastener Sealing** – allows fasteners to be designed within or outboard of the gasket more easily, reducing both EMI and moisture leakage into the enclosure through fastener holes.

- **Production Savings** – the gasket, cover and compression stops become a single part, reducing the number of purchased items, inventory and documentation.
- **Installation Savings** – inconsistent and expensive adhesive bonding operations are eliminated.
- **Field Reliability and Maintainability** – damaged gaskets or covers become a 1-part replacement with little potential for error. Also, conductive gaskets will not be replaced mistakenly with ordinary non-conductive gaskets during routine maintenance.

Finite Element Analysis (FEA) Optimizes Design

Chomerics has in-house FEA capability that offers significant time

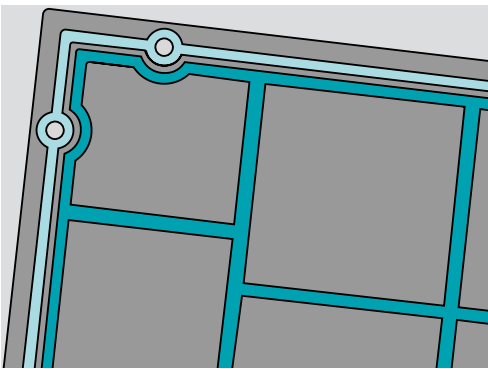

For large, complex gaskets with numerous “T” joints, an extruded gasket can be difficult to manufacture and requires adhesive bonding at every junction. A Molded-In-Place assembly provides a “seamless” gasket regardless of the configuration required.

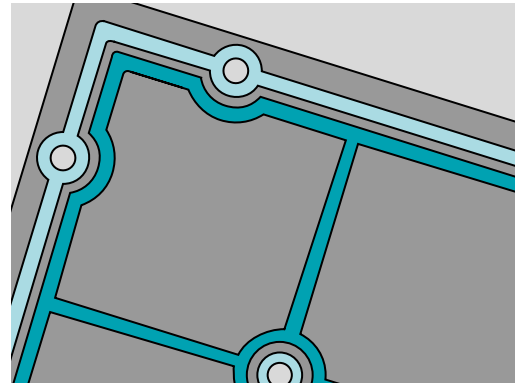

For electronic enclosures that require various compartments to be shielded from each other, a Molded-In-Place cover assembly provides maximum shielding effectiveness and simple installation.

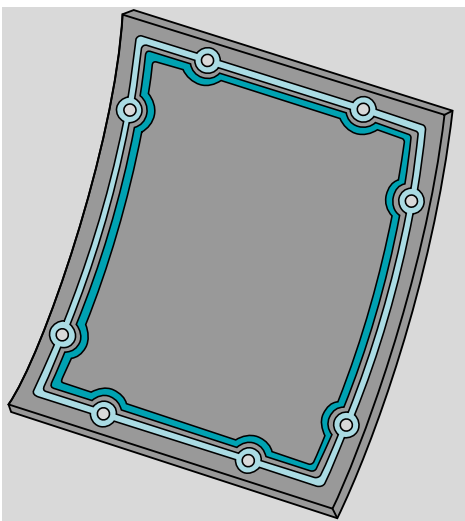

Enclosure covers with simple and compound curve configurations can also be supplied with Molded-In-Place elastomer gaskets.

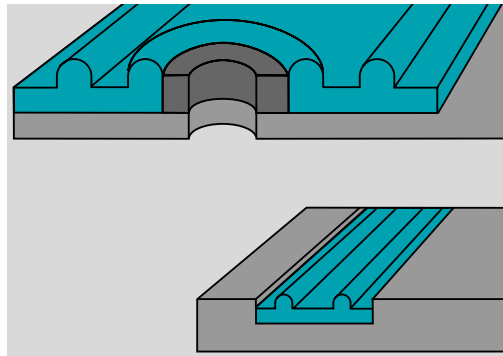

Molding-In-Place enables compression stops to be built directly into the gasket, protecting it from over-compression. Additionally, cover assembly shielding and environmental sealing performance can be improved even further by molding the gasket into a flange or cover groove.

Table 1

ELASTOMER SPECIFICATIONS FOR MOLDED-IN-PLACE COVER SEALS										
	Test Procedure (Type of Test)	CHO-SEAL 1215	CHO-SEAL 1217	CHO-SEAL 1285	CHO-SEAL 1287	CHO-SEAL 1298				
Grade		Military-Aerospace	Military-Aerospace	Military-Aerospace	Military-Aerospace	Military-Aerospace				
Type (Ref. MIL-G-83528)		Type A	Type C	Type B	Type D	Type D				
Elastomer Binder		Silicone	Fluorosilicone	Silicone	Fluorosilicone	Fluorosilicone				
Conductive Filler		Ag/Cu	Ag/Cu	Ag/Al	Ag/Al	Passivated Ag/Al				
Volume Resistivity, ohm-cm, max., as supplied (without pressure-sensitive adhesive)	MIL-G-83528 Para. 4.6.11	0.004	0.010	0.008	0.012	0.012				
Hardness (Shore A ±5)	ASTM D2240	65	75	65	70	70				
Specific Gravity (±0.25)	ASTM D792	3.5±0.45	4.1	1.9	2.0	2.0				
Tensile Strength, psi (MPa), min.	ASTM D412	200 (1.38)	180 (1.24)	200 (1.38)	180 (1.24)	180 (1.24)				
Elongation, %, min./max.	ASTM D412	100/300	100/300	100/300	60/260	60/260				
Tear Strength, lb/in. (kN/m), min.	ASTM D624	40 (7.00)	35 (6.13)	30 (5.25)	35 (6.13)	35 (6.13)				
Compression Set 70 hrs @ 100°C, %, max.	ASTM D395 Method B	32	35	32	30	30				
Low Temperature Flex, TR10, °C, min.	ASTM D1329	-65	-55	-65	-55	-55				
Maximum Continuous Use Temperature, °C*		125	125	160/200	160/200	160/200				
Shielding Effectiveness	200 kHz (H Field) 100 MHz (E Field) 500 MHz (E Field) 2 GHz (Plane Wave) 10 GHz (Plane Wave)	MIL-G-83528 Para. 4.6.12	dB, min.	70	70	60	55	55		
				120	120	115	110	110		
				120	120	110	100	100		
				120	115	105	95	95		
				120	110	100	90	90		
				120	110	100	90	90		
Electrical Stability	Heat Aging	MIL-G-83528 Para. 4.6.15	ohm-cm, max.	0.010	0.015	0.010	0.015	0.015		
				Vibration Resistance	MIL-G-83528 Para. 4.6.13	0.006	0.015	0.012	0.015	0.015
						0.004	0.010	0.008	0.012	0.012
				Post Tensile Set Volume Resistivity	MIL-G-83528 Para. 4.6.9	0.008	0.015	0.015	0.015	0.015
EMP Survivability, kA per in. perimeter	MIL-G-83528 Para. 4.6.16	>0.9	>0.9	>0.9	>0.9	>0.9				

* Where two values are shown, first represents max. operating temp. for conformance to MIL-G-83528 (which requires Group A life testing at 1.25 times max. operating temp.) Second value represents practical limit for exposure up to 1000 hours (compressed between flanges 7-10%). Single value conforms to both definitions.

and cost-saving benefits. This advanced computer simulation technology enables compression/deflection characteristics and other parameters to be evaluated and optimized *during the design phase*, without the delays of trial-and-error prototyping. FEA is routinely employed in the development of Molded-In-Place Cover Seals.

For additional information contact our Applications Engineering Department.

Ordering Information

Chomerics can Mold-In-Place any of the CHO-SEAL conductive elastomers described in Table 1. Select the material that meets the performance criteria for your application.

If you would like Chomerics to supply your total gasket/cover assembly, send a drawing of the

enclosure configuration to our Applications Engineering Department, along with your request for a quotation.

If you would like us to mold CHO-SEAL elastomers to an existing cover, send a drawing or actual cover sample for evaluation.

Note: Covers supplied for molding may require modification for tooling interface, and must be unpainted and unplated, but can be finished by Chomerics to your requirements.

Size Limitations

Chomerics can produce Molded-In-Place gasket/panel assemblies in any overall dimension larger than 3/4 x 3/4 in. (19 x 19 mm). Minimum recommended gasket profile cross section is 0.062 in. (1.6 mm), with a minimum thickness of 0.020 in. (0.5 mm) for flat gaskets. Smaller cross sections and thicknesses, although not recommended, can be accommodated.

Table 2 Non-Conductive Environmental Sealing Elastomers (Molded applications only)

SILICONE PER ZZ-R-765 CLASS 2A AND 2B		FLUROSILICONE PER MIL-R-25988 TYPE 2, CLASS 1	
Grade	Chomerics Product No.	Grade	Chomerics Product No.
40	2514	40	2524
50	2530	50	2526
60	2515	60	2529
70	2527	70	2534
80	2531	80	2535

Note: Contact Chomerics for information on Qualification and QC Conformance test data.